

MODELO 5000

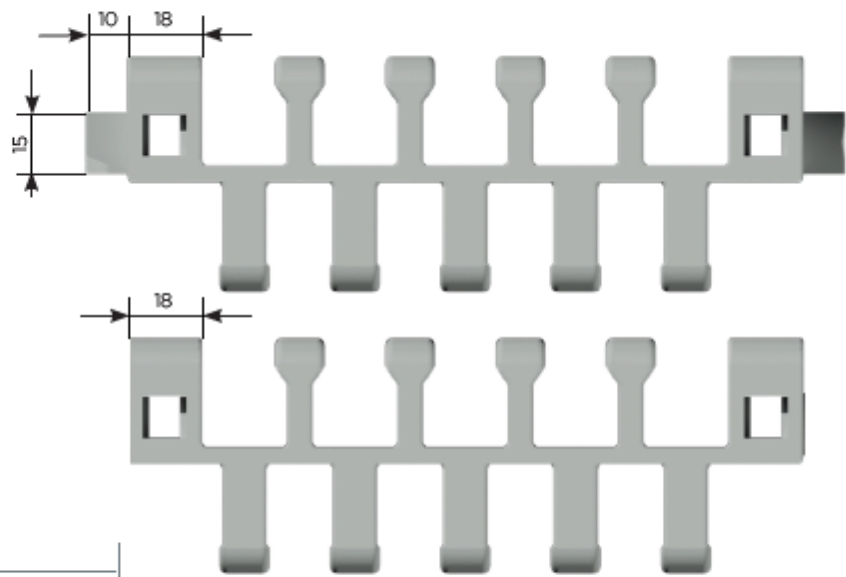

Modelo	Código
Sin Brazo	HC2.2-M-05000
Con Brazo	HC2.2B-M-05000

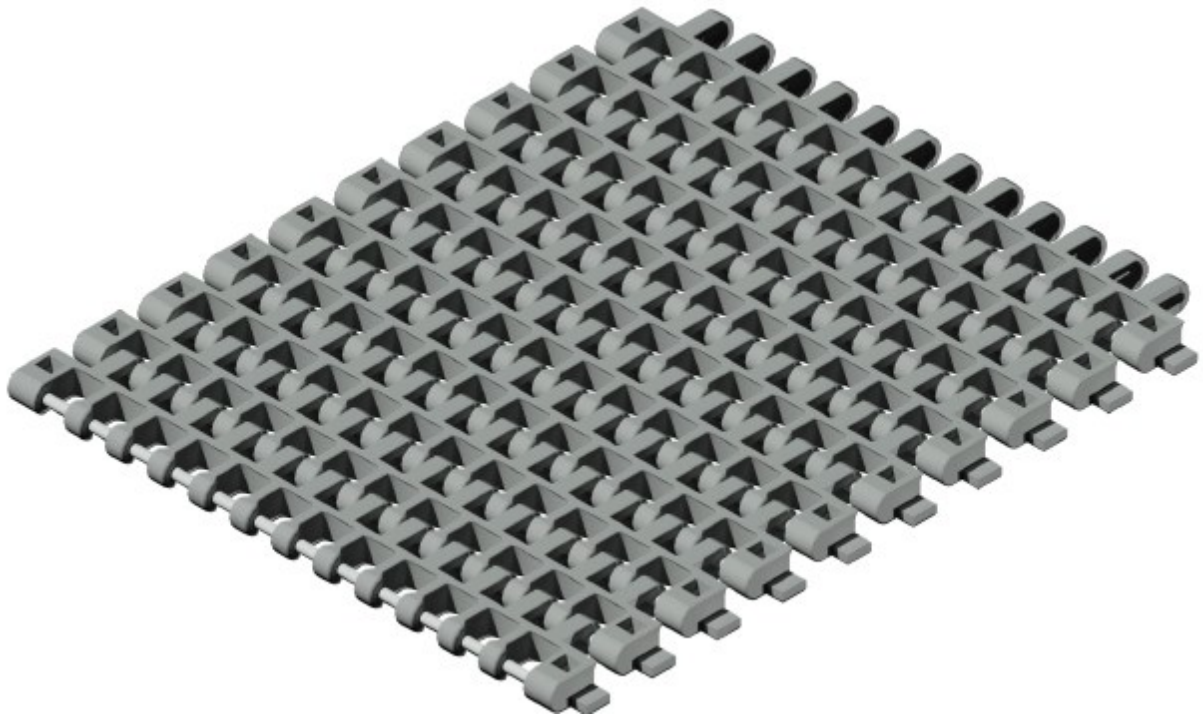

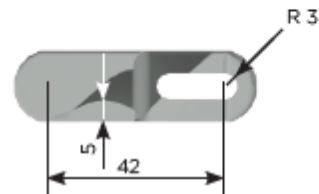

P5400 - HC2.2-M-05400

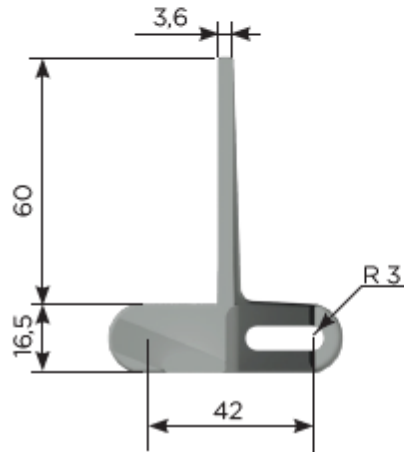
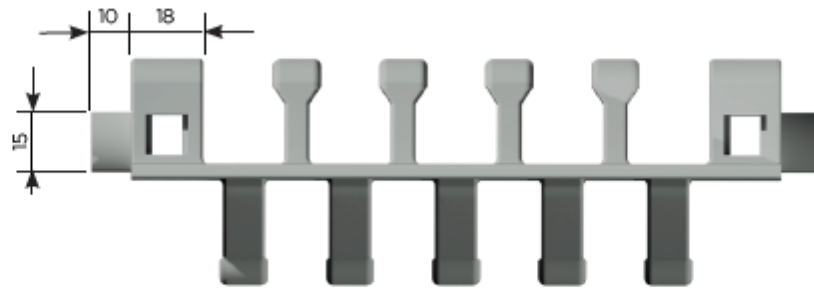

Z10 - Diámetro primitivo 135 mm

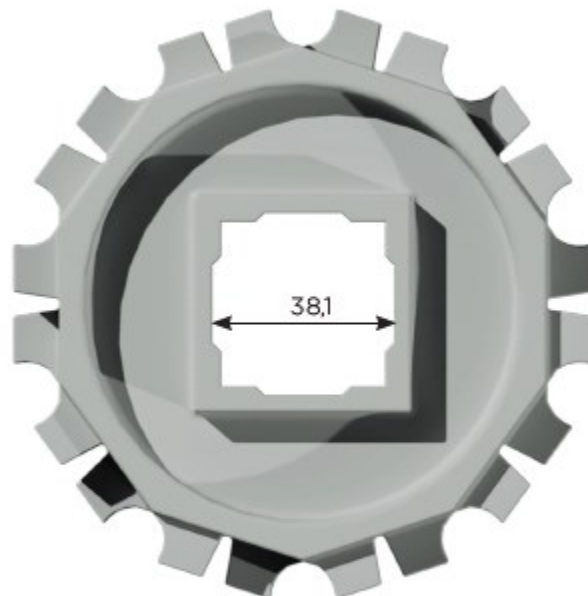
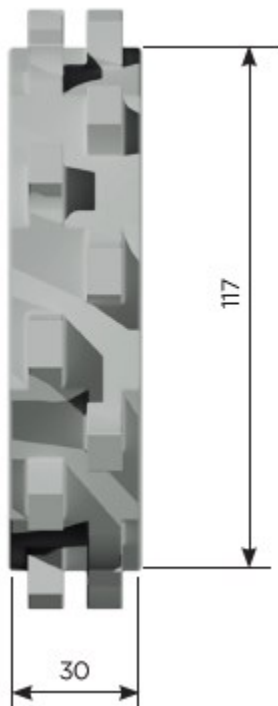



PERFÍL BARANDA SIN BRAZO LT-1A-PRF202138

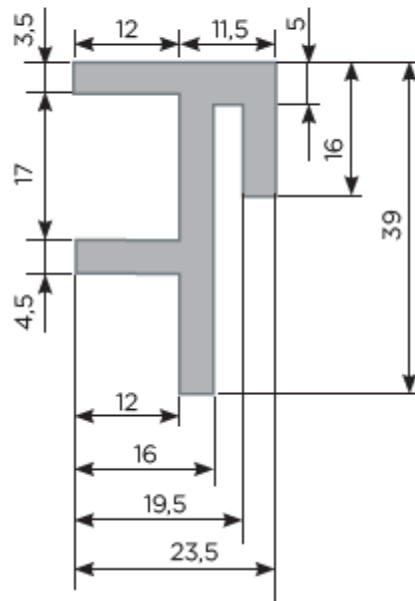

PERFÍL BARANDA CON BRAZO LT-1A-PRF202139

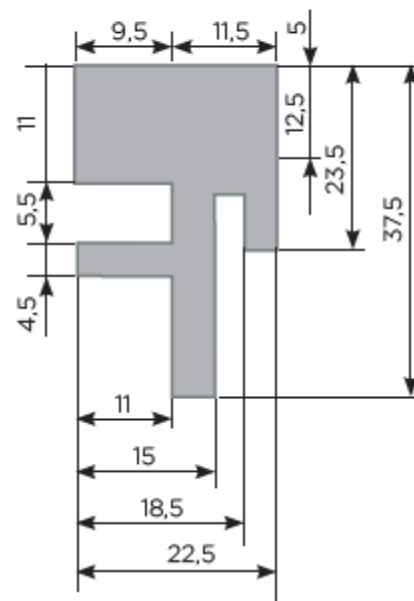

PUNTERA EJE MOTRIZ - HC2.2B-G-00800 - Con Brazo

Las punteras son accesorios fundamentales para el correcto funcionamiento de la banda curva y su función es guiar e introducir la banda al perfil de contención lateral F. Las mismas se colocan en la parte superior del transportador en el eje de retorno y en la parte inferior en el eje motriz.

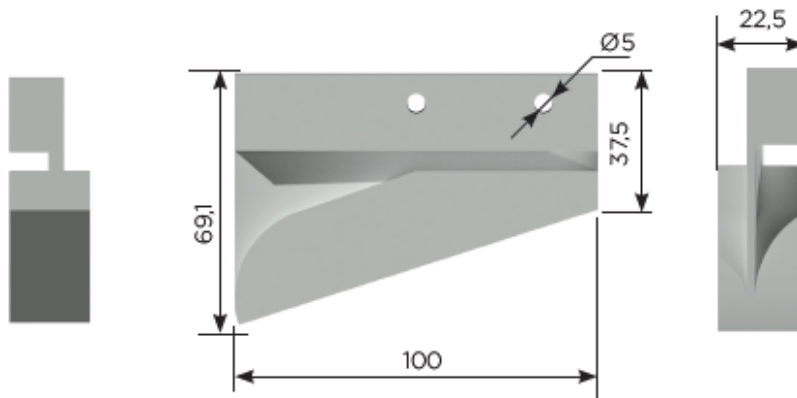

PUNTERA EJE RETORNO - HC2.2B-G-00810 - Con Brazo

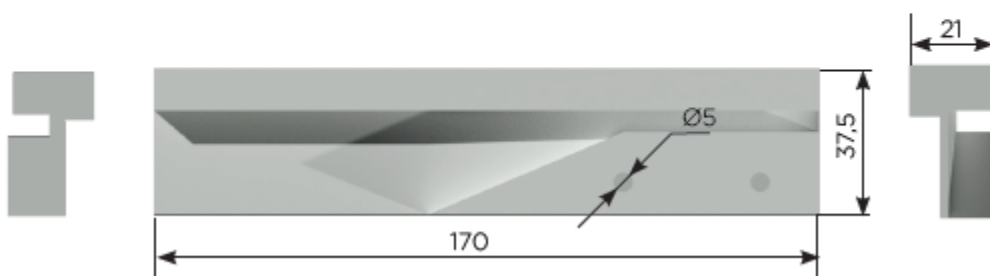



PUNTERA EJE MOTRIZ - HC2.2-G-00820 - Sin Brazo

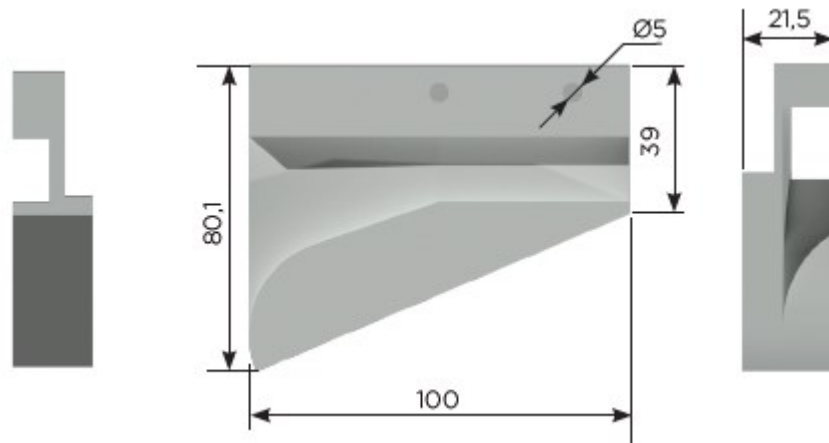

PUNTERA EJE RETORNO HC2.2-G-00830 - Sin Brazo

